

OPERATING INSTRUCTIONS

MANKAR



Models: MANKAR-ONE and MANKAR-TWO
all types of the S- and Flex-models

ULV- Applicator for weed control
in areas of specialised cultivation such as nurseries, orchards and vineyards, ornamental plant and vegetable gardens, as well as agricultural, forestry, communal and non-cultivated lands.

The unit has been developed for the *undiluted* application of ROUNDUP® products (Glyphosate).

Important:

Before application, carefully read the usage instructions for the unit and the plant protective agent!
Observe safety instructions!
For questions regarding plant protective agents, consult the manufacturer!
Observe the requirements and regional regulations for the use of herbicides and, if necessary, obtain approval from the responsible authorities (e.g. environmental conservation agency)!
Application is to be performed only by a competent user.

Remarks about usage of the unit:

Settings: This system is not suitable for the application of water.
Use herbicides for testing the spray action and calibration of the flow rate.

Usage: Position the spray hood directly above the ground –
if the spray hood is held too high, the danger of spray driftage exists.

Cleaning: Do not clean the unit with a high-pressure spray or an intense water jet spray.



Noise emission from the unit equates to less than 70 dB(A).

Manufacturer:

Mantis ULV-Sprühgeräte GmbH

Germany 21502 Geesthacht, Vierlander Str. 11 a

Telephone +49(0)4152-8459-0, FAX +49(0)4152-8459-11

Web: www.mantis-ulv.com Email: mantis@mantis-ulv.com

MANKAR Roll

For the undiluted application of Roundup® products (Glyphosate)

The information on this page applies to all MANKAR Roll units. Details regarding assembly, use and replacement parts are provided on the following pages:

MANKAR-ONE: Pages 4, 6-9

MANKAR-TWO: Pages 5-9

Intended usage:

Weed control in areas of specialised cultivation such as nurseries, orchards and vineyards, ornamental plant and vegetable gardens, as well as agricultural, forestry, communal and non-cultivated lands.

Before application, carefully read the usage instructions for the applicator unit and pesticides.

Observe safety instructions.

For questions regarding pesticides, consult the manufacturer.

Observe the requirements and regional regulations for the use of herbicides. Permission is required from the responsible authorities (e.g. environmental conservation agency) for the application of herbicides on surfaces used for non-agricultural, forestry or gardening purposes ("non-cultivated lands"). Application is not permitted on sealed surfaces (e.g. pavement surfaces) with connection to sewage water systems from which the danger of run-off exists!

Application may only be carried out by a competent user.

Noise emission from the unit equates to less than 70 dB (A).

Precautions

Observe the information in the pesticide usage instructions regarding user safety, and wear recommended body protection. Wear protective gloves when handling the chemical solution.

Do not eat, smoke or drink while working with pesticides.

Avoid any kind of chemical spillage. Thoroughly wash hands and face after completion of work.

Thoroughly clean and dry the unit immediately after use. Never use the mouth to blow out atomiser or other small parts!



Keep pesticide applicators and chemical substances away from children.

Assembly and preparation for first use

Unit assembly is described for the individual models.

Before using the unit for the first time, charge the battery for at least 16 hours.

Attention! Always follow the sequence:

1. Insert the plug jack into the charger socket.
2. Plug the charging unit into a 230 V mains socket.

The battery has reached its full voltage capacity after approx. 16 hours' charging time. When the charging process is complete, first unplug the charging unit from the 230 V socket and then remove the unit plug from the charger socket.

Spray duration when operating one rotating atomiser
with 1 battery, 6 V - 7 Ah approx. 16 hours

Spray duration when operating two rotating atomisers
with 1 battery, 6 V - 7 Ah approx. 8 hours

The spray width should subsequently be checked - ideally with a piece of cardboard laid out on the ground - and the flow rate adjusted (see below for details).

The battery should be recharged immediately after using the applicator unit.

General information about the function and use of the unit

Pesticides: This applicator unit was originally designed for the undiluted application of Roundup products (Glyphosate). Practical experience has shown, however, that other herbicides can also be used in conjunction with this technology. Considering the many products on the market with their differing formulas, it is not possible to provide a complete list with application rate recommendations. The following information about unit settings relate to Roundup UltraMax (Glyphosate 450 g/L). In general, all products with a comparable viscosity are suitable. If you want to use a product other than Roundup UltraMax, its application should be first tested on a small area. Usage instructions for the chosen herbicide must always be observed, along with local requirements.

Applicator unit function: Rotating atomisers are driven by means of a rechargeable battery. Metering on all the units mentioned is path-dependent and takes place by means of a wheel driven pump. Droplets are formed by the centrifugal force of the rotating atomiser. The droplets are discharged downwards by the rotating atomiser through an adjustable segment. Residual chemical solution in the tank not intended for application is approx. 50 ml. This residual fluid can be poured back into the original herbicide container.

Checking applicator unit function: Chemical solutions may flow quicker or slower due to temperature fluctuations, which is why the flow rates in the metering table should be checked and corrected as necessary. This system is not suitable for the application of water. Always use herbicides for testing the spray process and for calibrating the flow rate. Check the rotating atomiser on a daily basis for cleanliness and free turning motion. Check the output volume from time to time throughout the season.

Using the applicator unit: Adjust the height of the spray hood so that it is as close to the ground as possible - if it is set too high, the risk of spray driftage exists. During operation, chemical solution collects in the rotating atomiser reservoir and will continue to drip for approx. 30 seconds after the shut-off valve has been closed if the unit is tilted. In order to avoid damage to cultivated plants due to dripping, we recommend closing the shut-off valve at the end of a row, for example, then folding the spray hood upwards and waiting approx. 30 seconds until the reservoir has emptied.

Spray width

- Place an underlay (cardboard or paper) on the ground and prop up the unit on stands.
- Actuate the switch button while simultaneously turning the wheel and appraising the spray width obtained, initially at one location. The spray width must be set so that the droplets are discharged over the entire width of the spray hood. The optimal spray width under standard operating conditions is set by the manufacturer.
- In the event of deviations, the screw (F) can be loosened in order to move the width adjustment on the atomiser (see drawing).
- Further details regarding operating width adjustment can be found on the pages for the individual applicator units.

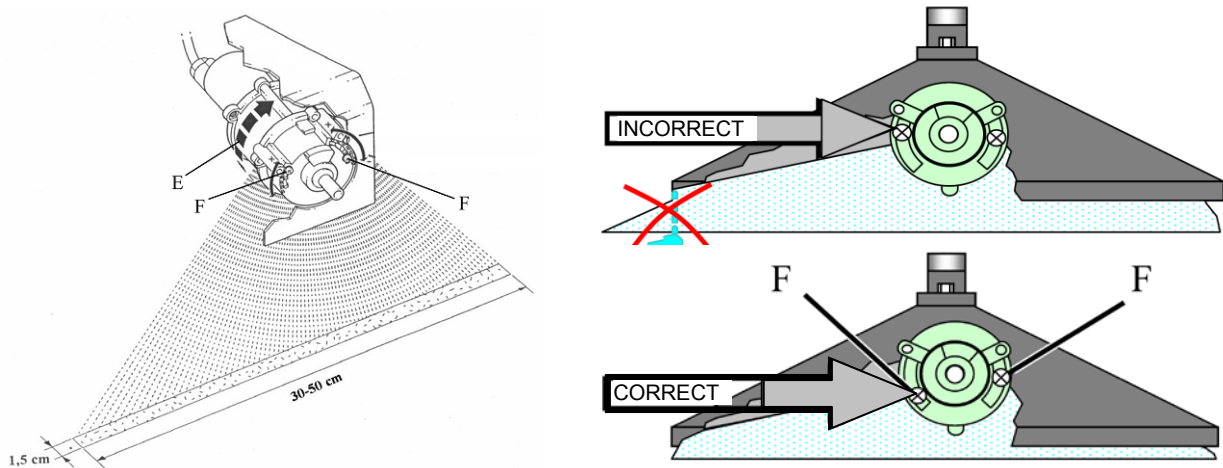

Cleaning

Do not clean the applicator unit with a high-pressure sprayer or an intense water jet spray.

Cleaning during the season: During short work breaks (a few hours), herbicide can remain in the system as long as the shut-off valve remains closed. After work completion: Before cleaning, drain the chemical solution and pour it back into the original container. Open the shut-off and set the metering pump to maximum. Fill the chemical solution tank up to halfway with water, then, with the unit positioned, turn the wheel smoothly approx. 50 x and allow the fluid to drain into a collector receptacle or, operating the unit for approx. 100 m, apply the cleaning fluid to the pre-treated surface. Remove any remaining water from the tank and turn the wheel approx. 50 x again until the system is completely empty.



Cleaning at the end of the season: Rinse the unit with warm water as described above. The spray hood and the atomiser housing can be cleaned with a damp cloth. Remove the atomiser disc in order to avoid damage. In the case of heavy contamination, the atomiser housing should be unscrewed to remove contaminants and plant parts. Connect the unit to the charging device (see below).

Charging the applicator unit and battery care

The applicator unit has an automatic charging device. Trickle charging is possible. Recharging a completely empty battery up to full capacity takes approx. 16 hours. The battery should be recharged immediately after use.

Battery charge	Min. charging time	Time interval
Fully discharged	16 hours	Immediately
Short-term use	6 hours	Immediately
Storage without use	(2 hours 1 x per month)	or charge continually

With a fully charged battery, units with one atomiser can be used for 16 hours, while units with 2 atomisers can be used for approx. 8 hours.

MANKAR-ONE 45
MANKAR-ONE-S Flex

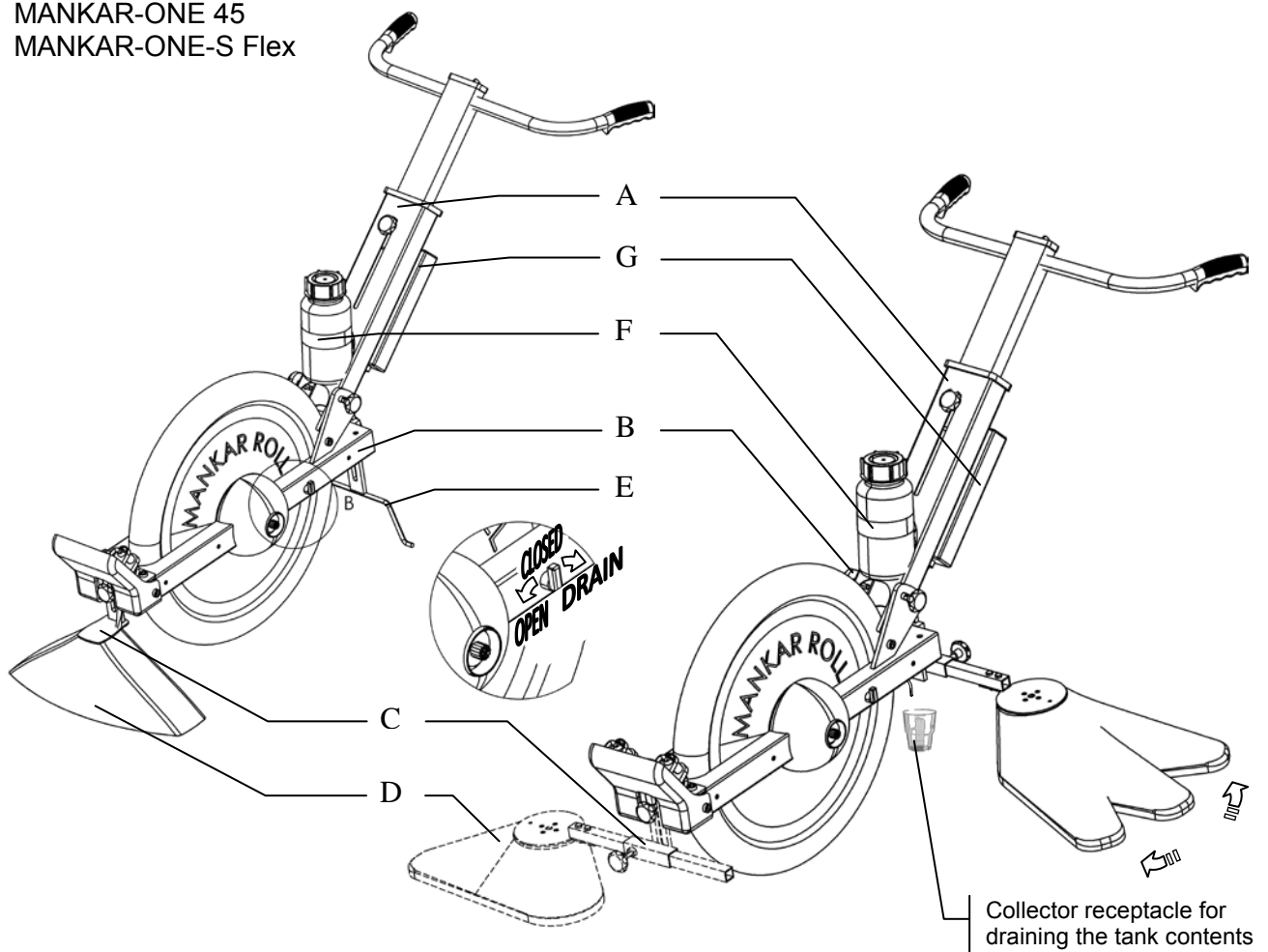

Assembly

1. Mount handle bar guide (A) on frame pump carrier (B).
2. Screw height adjustment (C) on to spray hood (D).
3. Fit height adjustment (C) to frame pump carrier (B) in front of or behind wheel.
4. Screw support stand (E) on to frame (in front of or behind wheel depending on position of hood).
5. Connect tank from holder (F) to pump intake hose.
6. Connect chemical solution hose from hood (D) to hose from frame pump carrier (B)
7. Connect atomiser cables for spray hoods (D) to cable harness from frame pump carrier (B).
8. Connect cable harness for frame pump carrier (B) to power pack (G)

Metering table

Roundup application rate at 20 °C

Metering adjustment knob position	Spray width in cm								
	20	25	30	35	40	45	50	55	
Litres per ha	1	-	-	-	-	-	-	A	A
	2	-	A	B	C	D	E	F	G
	3	B	D	E	F	H	I	J	K
	4	D	F	H	J	K	M	N	O

Checking the output volume

1. Place an underlay (e.g. cardboard or paper) on the ground and prop up the unit on stands.
2. Fill the chemical tank with herbicide - undiluted.
3. Disconnect the hose from the spray hood and place a measuring cup underneath.
4. Open the shut-off valve, initially setting the metering adjustment knob to the maximum flow rate and simultaneously turning the wheel; wait until the chemical solution is evenly applied.
5. Set the chemical solution volume according to the output table.
6. Volume calibration: Collect the chemical solution from 50 wheel revolutions in a measuring cup. If the desired volume is not reached, set a larger or a smaller volume with the pump metering adjustment knob.
7. Perform volume calibration again.
8. Reconnect the hose to the spray hood.
9. The unit is now ready for use.

Maximum allowable wheel pressure 2.5 bar

MANKAR-TWO Flex

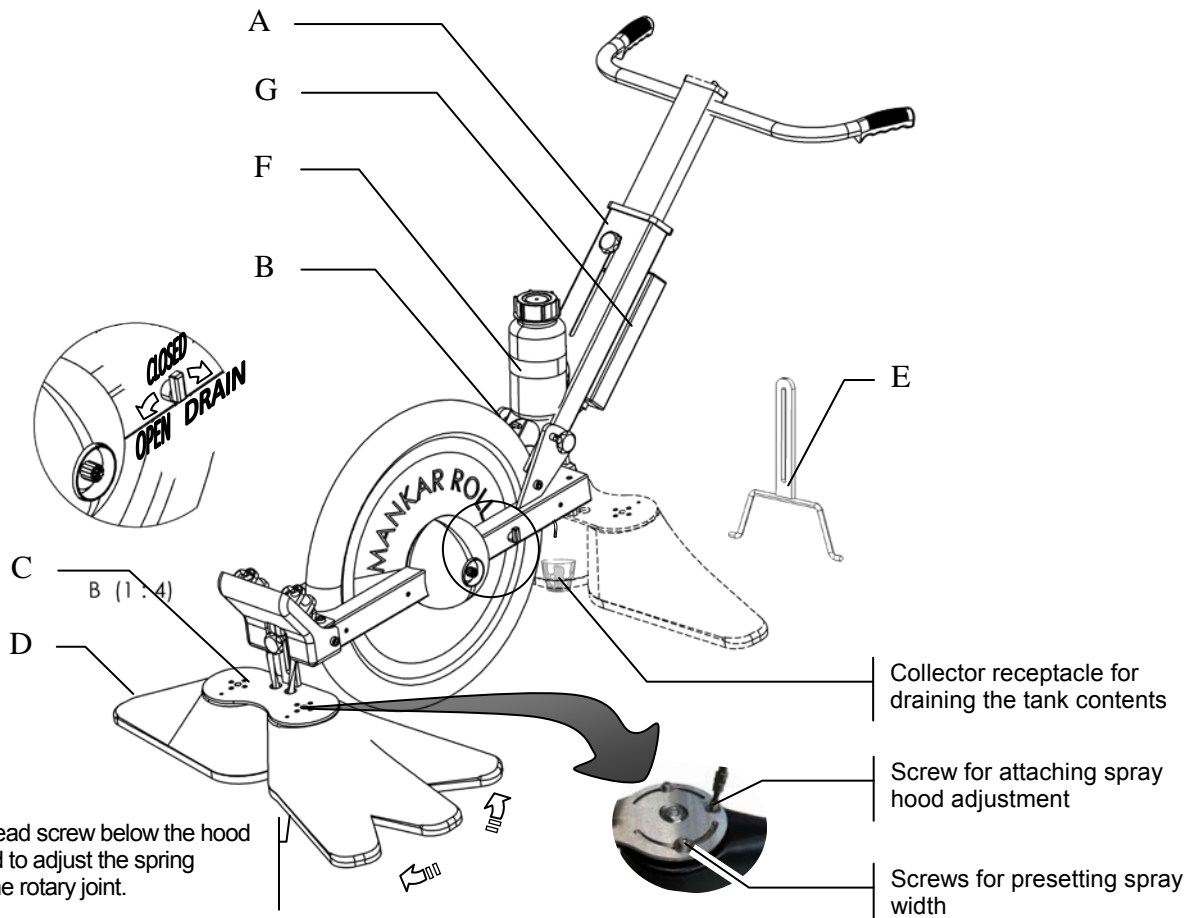

Assembly

1. Mount handle bar guide (A) on frame pump carrier (B).
2. Screw height adjustment (C) on to spray hood (D).
3. Fit height adjustment (C) to frame pump carrier (B) in front of or behind wheel.
4. Screw support stand (E) on to frame (in front of or behind wheel depending on position of hood).
5. Connect tank from holder (F) to pump intake hose.
6. Connect chemical solution hose from hood (D) to hose from frame pump carrier (B)
7. Connect atomiser cables for spray hoods (D) to cable harness from frame pump carrier (B).
8. Connect cable harness for frame pump carrier (B) to power pack (G)

Metering table

Roundup application rate at 20 °C

Metering adjustment knob position	Spray width in cm								
	40	50	60	70	80	90	100	110	
Litres per ha	2				A	B	C	D	E
	3		A	C	D	E	F		
	4	B	D	E					

Checking the output volume

1. Place an underlay (e.g. cardboard or paper) on the ground and prop up the unit on stands.
2. Fill the chemical tank with herbicide - undiluted.
3. Disconnect the hose from the spray hood and place a measuring cup underneath.
4. Open the shut-off valve, initially setting the metering adjustment knob to the maximum flow rate and simultaneously turning the wheel; wait until the chemical solution is evenly applied.
5. Set the chemical solution volume according to the output table.
6. Volume calibration: Collect the chemical solution from 50 wheel revolutions in a measuring cup. If the desired volume is not reached, set a larger or a smaller volume with the pump metering adjustment knob.
7. Perform volume calibration again.
8. Reconnect the hose to the spray hood.
9. The unit is now ready for use.

Maximum allowable wheel pressure 2.5 bar

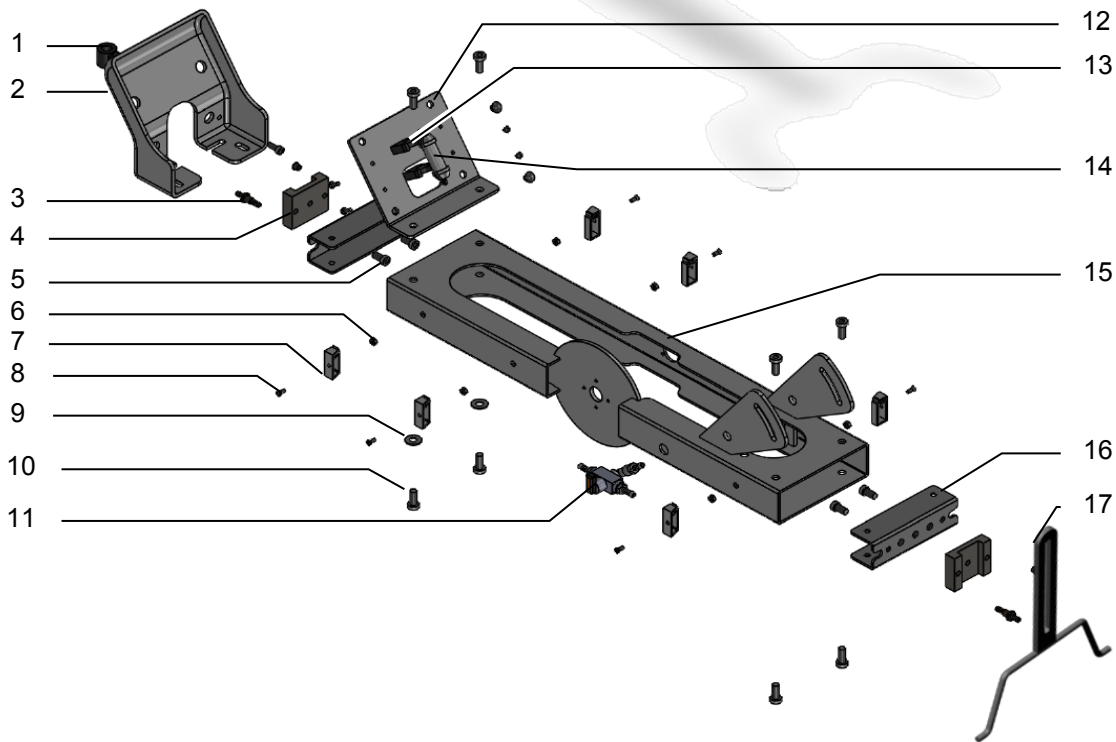
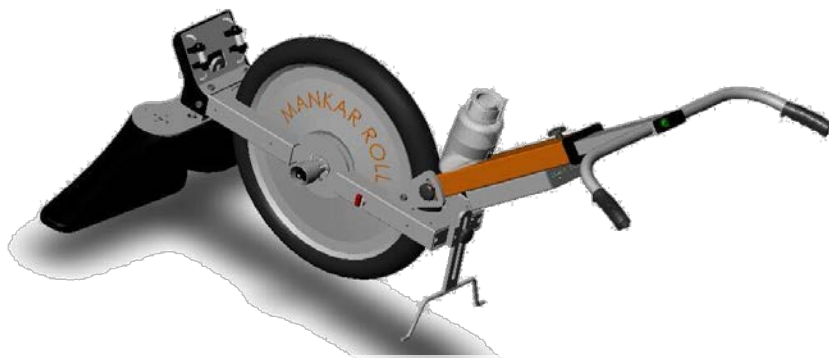

Part Art. No. Designation

1	102530	Clip for ITT SURE-SEAL, connector
2	104132	Protective cover, front Mankar-Roll
3	100085	Hose grommet 6 mm MS for pump sets MAFEX / MANKAR
4	104151	Mounting plate height adjustment Mankar-Roll
5	101145	Allen head screw M 8 x 16 mm VA
6	101209	Nut M 4, VA
7	104170	Cable holder, plastic Mankar-Roll
8	100998	Countersunk Philips head screw M 4 x 12 mm VA
9	100992	Washer M8, Ø8.4 mm, VA
10	101145	Allen head screw M 8 x 16 mm VA
11	104140	3-way ball valve Mankar-Roll
12	104130	Flow controller mount Mankar-Roll
13	104131	Flow controller clips Mankar-Roll
14	103319	Flow controller cpl. PC, HQ PC-glass 35.0 mm
15	104100	Frame pump carrier Mankar-Roll
16	104150	Adapter frame Mankar-Roll
17	104600	Stand Mankar-Roll

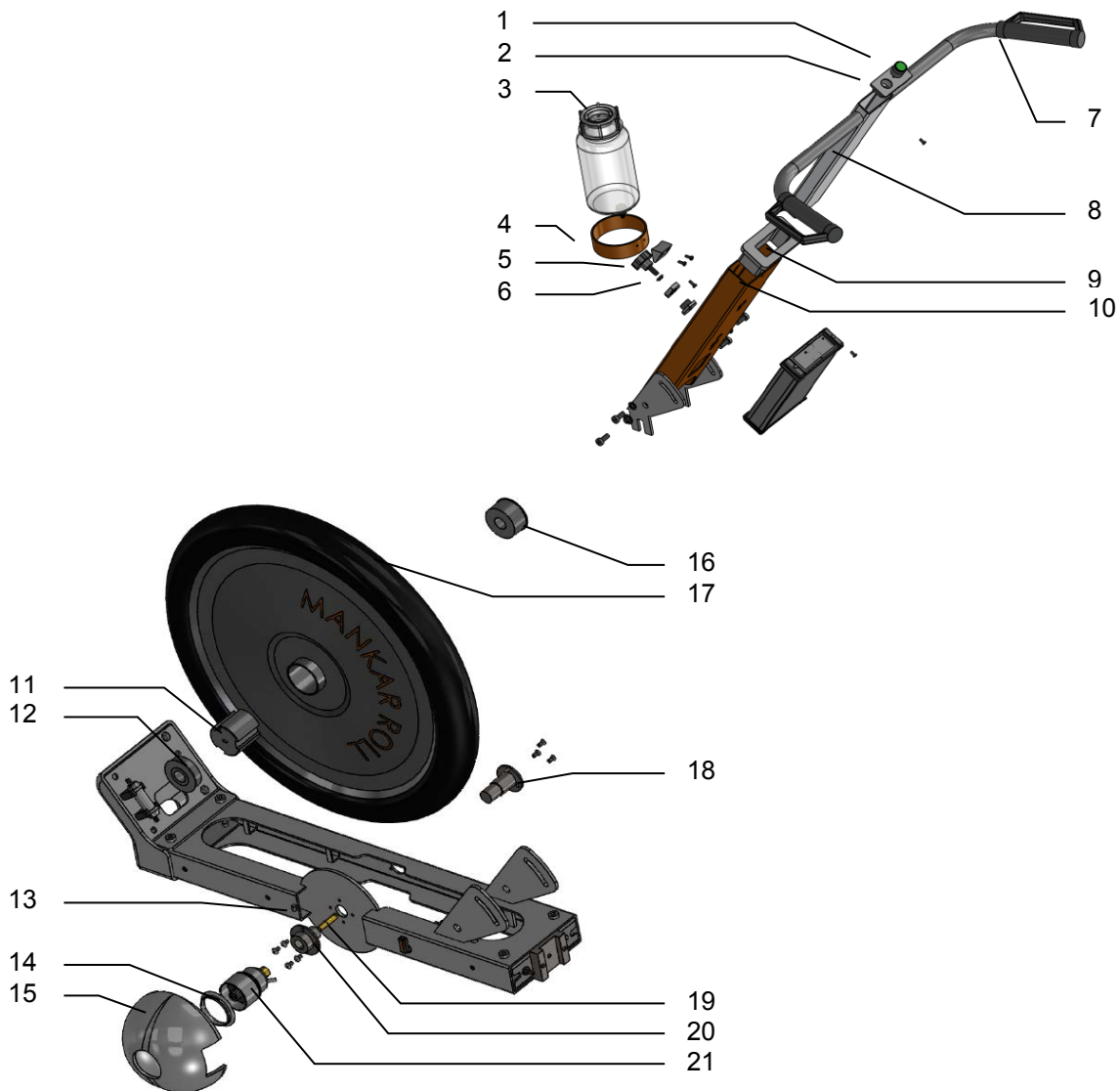

Part Art. No. Designation

1	102974	Pressure switch, green light, (round) for MANTRA and MANKAR Roll
2	104431	Handle bar cover Mankar-Roll
3	100441	Tank lid, 1 L with hole for MANKAR units
4	104240	Tank holder 1 litre Mankar-Roll
5	104250	Star knob screw M8 for Mankar-Roll
6	100992	Washer M8, Ø8.4 mm, VA
7	103724	Rubber hand grip for MANKAR
8 a	104400	Handle bar complete Mankar-Roll
8 b	104401	Handle bar complete Mankar-Roll Smaller version of the handlebar
9	104230	Handle bar bushing Mankar-Roll
10	104200	Handle bar guide Mankar-Roll
11	104501	Fully suspended drive flange Mankar-Roll
12	104502	Friction bearing, left Mankar Roll
13	104100	Frame pump carrier Mankar-Roll
14	104161	Pump protection ring Mankar-Roll
15	104160	Pump protection Mankar-Roll
16	104503	Friction bearing, right Mankar Roll
17	103477	Wheel 530 x 60 mm, pneumatic-tyred, Mankar-Roll
18	104112	Axle, right Mankar-Roll
19	104510	Propeller shaft Mankar-Roll
20	104111	Axle, left Mankar-Roll
21 a	100527	Metering pump MANKAR-3, capacity 5 - 12 ml/min for MANKAR-110 GP
21 b	100492	Metering pump MAFEX-3, capacity 2 - 20 ml/min

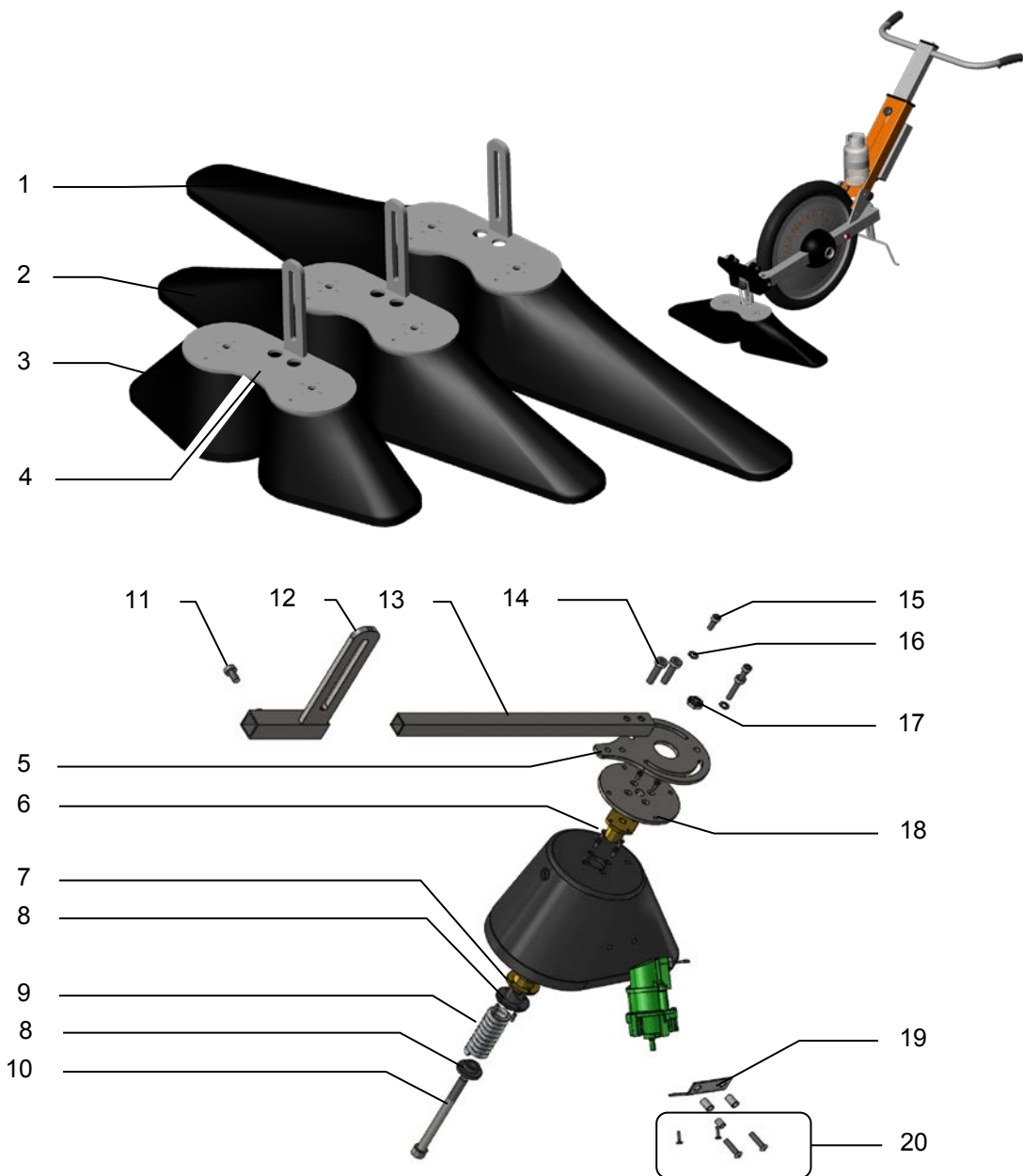

Item Part No. Description

1	104855	Spray hood 55 cm Mankar-Roll without atomiser
2	104840	Spray hood 40 cm Mankar-Roll without atomiser
3 a	104825	Spray hood 25 cm, right Mankar-Roll without atomiser
3 b	104824	Spray hood 25 cm, left Mankar-Roll without atomiser
4	104702	Height adjustment TWO Mankar-Roll
5	104730	Spray hood holder (S) One, Flex Mankar-Roll
6	104311	Mounting bush, rotary-joint Mankar-Roll
7	104313	Intermediate bush, rotary-joint Mankar-Roll
8	104315	Spring retainer for pressure spring Mankar-Roll
9	104314	Pressure spring, rotary-joint Mankar-Roll
10	104316	Bolt, Allen key 10 x 130 mm, VA Mankar-Roll
11	101145	Allen head screw M 8 x 16 mm VA
12	104701	Height adjustment ONE Mankar-Roll
13	104731	Width adjustment, ONE, ONE-S Mankar-Roll
14	103826	Allen head screw M 6 x 45 mm VA
15	103467	Filister head screw M 6 x 12 mm VA with Allen head
16	101868	Washer M6, Ø6.4 mm, 3D VA
17	103428	Nut, pressed, M10, hexagonal, VA
18	104740	Rotary disc, spray hood Mankar-Roll
19	104811	Atomiser bracket, spray hood Mankar-Roll
20	104989	Screw kit atomiser bracket MANKAR-Roll

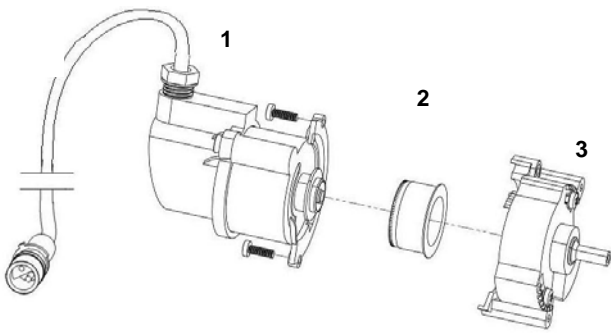

Item Part No. Description

103824 Atomiser for MANKAR-TWO Flex

1	103825	Motor-module for atomiser MANKAR-TWO Flex
2	100478	Atomiser disc for segment atomiser
3	101996	Segment-module for segmental atomiser incl. width adjustments

103947 Atomiser for MANKAR, One-S, Two-S, Flex

1	103946	Motor-Modul for atomizer MANKAR, One-S, Two-S
---	--------	---

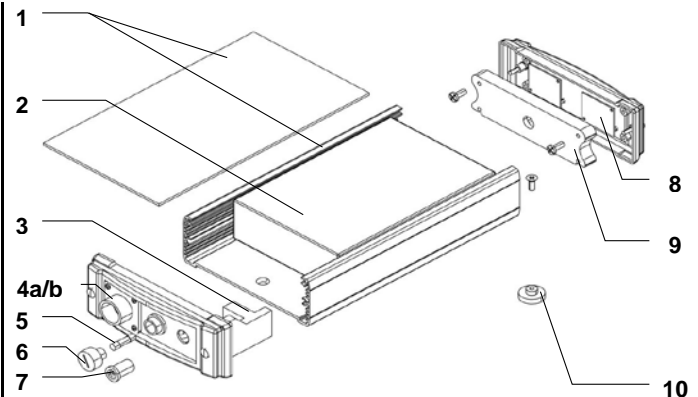

Item Part No. Description

**104225 Mankar-ONE, powerpack
104224 Mankar-TWO, powerpack**

1	104220	Power pack housing Mankar-Roll
2	100450	Storage battery 6V - 7Ah for MANKAR-Roll and Mini-Mantra
3	104222	Spacer, power pack Mankar-Roll
4a	104940	Cable set, power pack Mankar-One
4b	104941	Cable set, power pack Mankar-Two
5	100730	Fuse T3.15 Amp
6	100747	Fuse holder for glass fuse
7	100693	Socket, d=2,1 mm
8	103286	Elektronik, monitor with LED for MANKAR HQ and Roll
9	104221	Mount for monitoring LED Mankar-Roll
10	104223	Mount, plastic, power pack Mankar-Roll

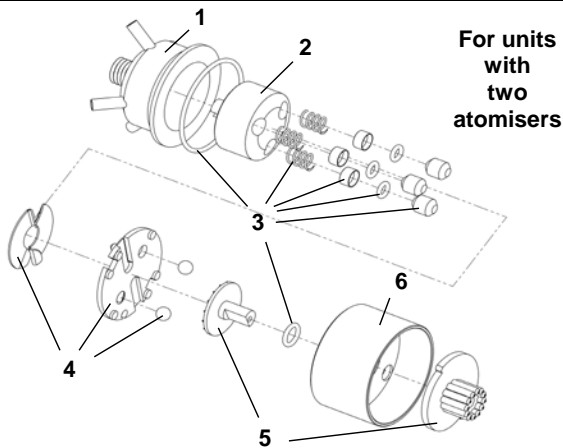

Item Part No. Description

100527 Metering pump MANKAR-3, capacity 5 - 12 ml/min for MANKAR-110 GP

1	100528	Pump housing for two-channel pump Metering pump MANKAR
2	102209	Rotor-3, chromed brass for piston pump MAFEX/MANKAR
3	102373	Sealing set for metering pump MANKAR-3/MAFEX-3
4	101626	Repair set, metering pump MANKAR, pressure plate/wobble plate
5	102429	Repair set, metering pump MANKAR, metering adjustment knob/ selector disc
6	100534	Cover for piston pump MAFEX/MANKAR

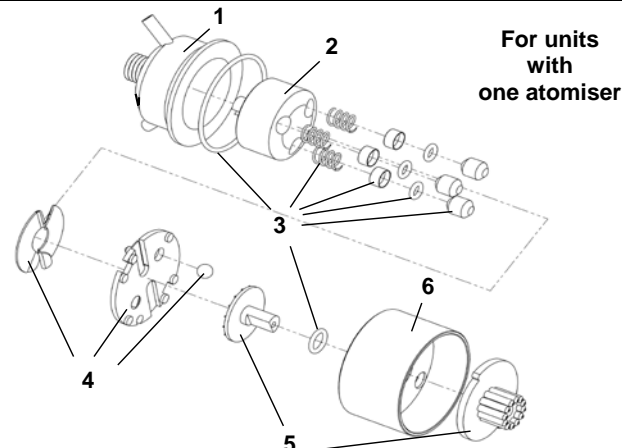

Item Part No. Description

100492 Metering pump MAFEX-3, capacity 2 - 20 ml/min

1	100493	Pump housing for single-channel pump Metering pump MAFEX
2	102209	Rotor-3, chromed brass for piston pump MAFEX/MANKAR
3	102373	Sealing set for metering pump MANKAR-3/MAFEX-3
4	102436	Repair set, metering pump MAFEX, pressure plate/wobble plate
5	102437	Repair set, metering pump MAFEX, selector/adjustment knob
6	100534	Cover for piston pump MAFEX/MANKAR

**Dosierpumpe MANKAR
Metering pump MANKAR
Pompe doseuse MANKAR**

**Druckseite
Pressure sleeve
Pression**

**Saugseite
Sucking sleeve
Aspiration**

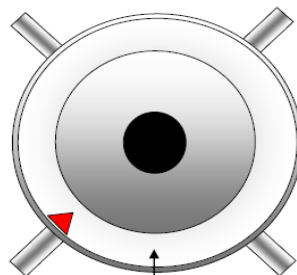

**Saugseite
Sucking sleeve
Aspiration**

**Druckseite
Pressure sleeve
Pression**

**DOSIERKNOPF
Metering adjustment knob
Réglage de débit**

**Dosierpumpe MAFEX
Metering pump MAFEX
Pompe doseuse MAFEX**

Druckseite / Pressure sleeve / Pression

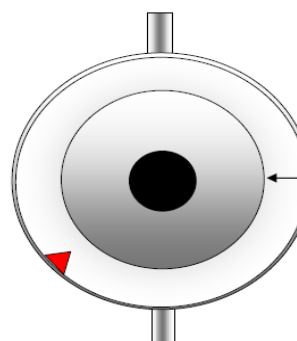

**DOSIERKNOPF
METERING
ADJUSTMENT KNOB
RÉGLAGE DE DÉBIT**

**Saugseite
Sucking sleeve
Aspiration**

Troubleshooting

Fault	Cause	Rectification
Atomiser disc does not rotate	Atomiser contaminated	Thoroughly clean atomiser, remove plant parts as necessary
	Battery empty Fuse blown	Charge battery Replace fuse on power pack (Replacement fuses are located in the power pack housing)
	No electrical contact Battery faulty Atomiser motor faulty	Check cable and connector contacts Install new battery Install new motor Connect the brown cable to Plus (+).
Atomiser spray one-sided	Incorrect width setting	Undo screws (F, see page 3) and adjust the width setting to the left or right
Atomiser drips	Metering valve incorrectly adjusted	Check setting, see table
	Atomiser disc faulty/contaminated	Replace/clean disc
	Atomiser spray discharge contaminated	Clean
Atomiser foams	Residual water in the system	Completely empty tank, hose and segmental atomiser.
Air in hose	Hose connection not airtight	Shorten the hose slightly and fit it on the hose nipple.

Metering pump does not draw

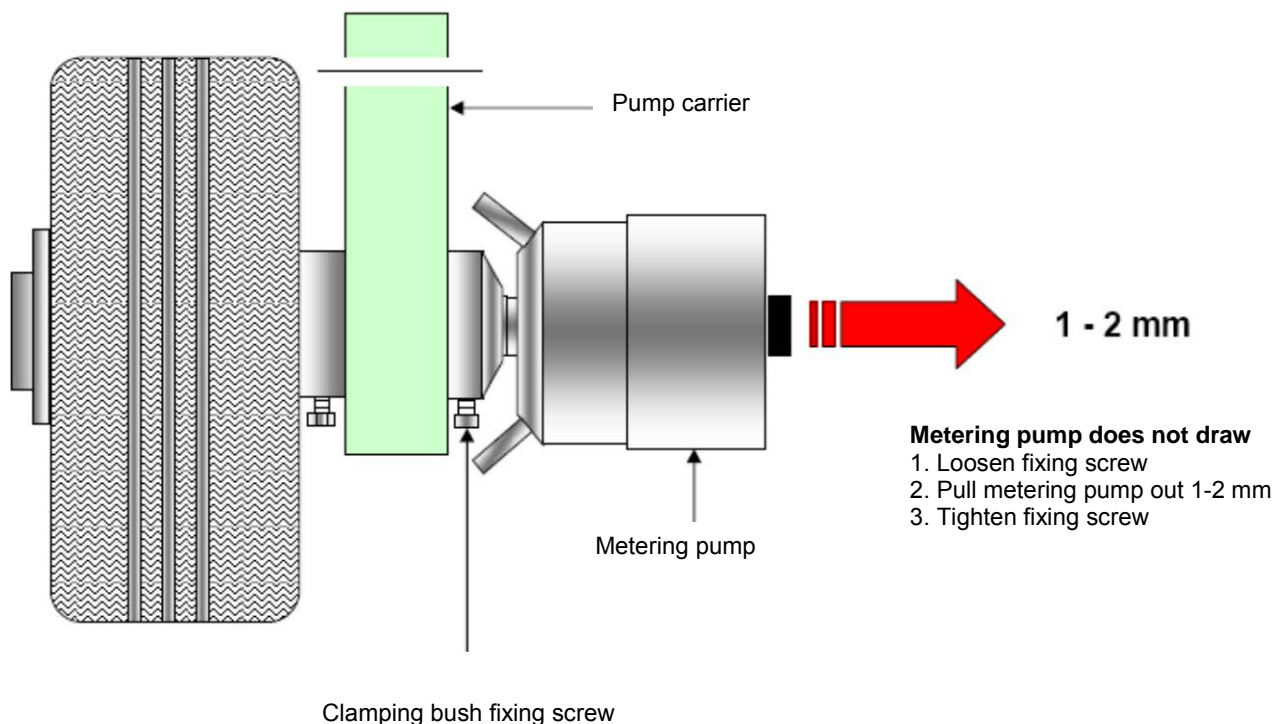

EG-Declaration of conformity Council Directive 2006/42/EG

Mantis ULV-Sprühgeräte GmbH, Vierlander Straße 11 a, 21502 Geesthacht declare under our sole responsibility that the following products are in conformity with the provisions of the following Council Directive: 2006/42/EG

Typ MANKAR-ONE, MANKAR-TWO

Hiske Weissmann
Managing Director

Geesthacht January 2020

(Place and date of signature)



(Name, title and signature)